



Rules

2024

(Twenty-seventh year)

Visa FFM N° 2024 / 8

Warning :

**This Regulation is a translation of the original official French text.
In case of conflict of interpretation, the official French text shall prevail.**

General Rules of the “Challenge des Monos”

Article 1 : Definition

In 2024, the CM2 association will organise the Challenge des Monos, under the aegis of the F.F.M. This challenge is reserved for the owners of machines meeting the specifications of the technical regulations below.

A distinction will be made between machines meeting the criteria of "Supermono" or "Mono2".

These rules are an amendment to the F.F.M. rules. Any dispute will be settled in accordance with the FFM sporting code, the CNV general rules, the regulations of the host event and these regulations.

Article 2 : Participants

1 – Admission requirements :

These events are open to all riders holding a valid NCO or LUE licence issued by the F.F.M.

Day licences are accepted without ranking.

The organisers reserve the right to invite any rider who holds a valid F.F.M. competition licence to compete in the event.

2 – Special provisions for beginner riders :

Any rider participating for the first year in the Challenge des Monos and unable to justify a previous participation in a speed race organised under the aegis of the F.F.M. or a foreign federation is considered as a beginner.

Beginner riders will wear a fluorescent yellow safety vest during their first participation in a **Challenge des Monos** race.

Thereafter, the organisation reserves the right to impose the wearing of this safety vest.

Article 3 : Events

The **Challenge des Monos** will be held in all the events on the calendar.

Each event will consist of 2 races.

All results will be taken into account for the general ranking.

The provisional timetable is annexed to this Regulation.

During the events, competitors are reminded that their motorbikes and equipment are under their full responsibility throughout the event.

In particular, they must ensure constant watch on them and may under no circumstances invoke the civil liability of the **CM2** association or the organising club in the event of theft or damage.

Article 4 : Registration and Commitment

Any rider wishing to participate in the Challenge des Monos must fill in the registration form (valid as membership of the CM2 association) and pay the corresponding fees.

All information concerning registration and participation fees are given in the appendix to these rules.

All payments should be made by cheque or bank transfer to CM2.

1 – Registration 2024 for the **Challenge des Monos** :

The application for the 2024 Challenge des Monos must be accompanied by the payment of the registration fee made out to CM2 (application to be downloaded from challengedesmonos.fr) and sent to the address indicated in the annex.

Important : The category in which the rider competes must be determined at the time of registration for the 2024 Challenge des Monos.

Any race done with a motorbike not corresponding to the category chosen at the time of registration will only give right to points in Supermono for this race.

Trial package :

It is possible to enter a race of the Challenge des Monos on a trial basis without being registered for the year. The driver will then have to pay the corresponding entry fee as shown in the appendix. The registration to the race does not give the right to the attribution of points.

The registration will be retained subject to sufficient places, the riders regularly registered in the Challenge des Monos having priority.

The application form, together with cheques made payable to CM2, should be sent to the address given in the annex.

2 - Deposit :

For riders participating in the **Challenge des Monos**, a deposit by cheque for the amount shown in the appendix, made out to **CM2**, must accompany the registration form.

This payment will be kept throughout the season and will only be cashed in the event of loss or damage to the transponder. In this case, a new deposit will be requested.

3 - Race entries :

Applications for entries must be sent by unregistered mail no later than 21 days before the date of the event to the address given in the appendix.

Entries are open 60 days before the date of the event.

However, applications for all events may be sent at the beginning of the season.

The entry form must be accompanied by payment to the order of the CM2, the amount of which is shown in the appendix to these rules.

Cheques will be cashed as follows :

- The subscription cheque is cashed on receipt and is not refundable.
- The reservation cheque is cashed at the opening of registrations (60 days before the date of the event) and is not refundable.
- The registration cheque will be cashed after the event.

Trial" formula:

It is possible to enter a **Challenge des Monos** race on a trial basis without being registered for the year. The driver must then pay the corresponding entry fees shown in the appendix. Entry in the race does not entitle the rider to points.

Entries will be accepted subject to there being sufficient places available, with drivers regularly registered for the **Challenge des Monos** being given priority.

In case of withdrawal, the rider must inform the organisation at the latest on the Sunday before the event.

Applications will be ranked in order of submission. Once the quota of participants is reached according to the capacity of the track and the event, the following applications will be placed on a waiting list. The riders on the waiting list will however be able to participate in the qualifying practice within the limit of the track capacity. In the event that a regularly registered rider withdraws, the rider on the waiting list may participate in the races, his place on the grid being determined by his qualifying time.

For applications returned after the closing date for entries, i.e. 21 days before the event, the entry fee will be increased by the amount shown in the annex.

Warning : Any incomplete application will be returned in its entirety to the sender. It is the responsibility of the rider to return the completed application with the corresponding cheques **within the time limit** to be able to participate in the event.

Any application sent by registered mail will be refused.

No confirmation will be sent.

The timetable and the list of registered and waiting drivers will be available on the challengedesmonos.fr website at least 7 days before the beginning of the event.

Article 5 : Administrative checks

Each rider must present **himself** at the administrative control **during the time slot indicated on the challengedesmonos.fr website** with his valid licence.

Article 6 : Technical checks

Each rider must present :

- **His motorbike without the lower fairing and tank ready to be dismantled, these elements will be presented to the controllers.**

- Its helmet meets European standards ECE 22-05 and ECE 22-06 and is no more than 5 years old (WARNING: THE ECE 22-05 STANDARD WILL BE PHASED OUT IN 2026). A full-face helmet with visor must be worn. Modular helmets, off-road helmets and jet helmets are not allowed.
- Its 1-piece leather suit. Synthetic lining is forbidden, except for the wearing of full cotton, nomex or silk underwear.
- His leather gloves and boots in good condition
- Its back protection complies with EN 1621-2.
- It is recommended that you wear an FFM-standard airbag.

Beginner riders must also present :

- A fluorescent yellow safety vest

An F.F.M. licensed technical marshall shall check the equipment and machines and verify their conformity with the technical regulations.

No one shall be allowed to race if he has not passed the technical and administrative checks.

N.B. : THE MARSHALLS ARE VOLUNTEERS, PLEASE MAKE YOURSELF AVAILABLE TO THEM.

Article 7 : Mandatory Briefing

A briefing will be organised by the **CM2** association before the start of each event. It will take place after the first jury meeting of the event, generally at **around 7.30 p.m.** The exact time will be specified at the time of the controls.

The presence of each rider OR HIS REPRESENTATIVE is mandatory during the briefing.

An attendance sheet will be drawn up and each driver or his representative must sign. Any unjustified absence from the briefing will be penalised by a 20 second penalty on the first race of the event.

Article 8 : Qualifying

Qualifying will be carried out in 2 rounds of 20 minutes each.

All drivers who have completed at least one timed lap with no minimum requirement will be qualified.

Drivers on the waiting list who have taken part in the qualifying practice will only be able to take part in the races if a regularly registered driver withdraws.

The time trials will be used to establish the starting grid for the races, based on the best times recorded.

The composition and number of practice rounds will be displayed on the **CM2** organisation board. The number of qualified riders may not exceed the maximum capacity of the track.

Riders whose best time is higher than 120% of the average of the best times of the first three qualified drivers must wear a yellow fluorescent safety vest during the races.

Article 9 : Race starts

The start will be made with the engine running. The riders will be placed on the starting line according to the grids published by the organisation.

Article 10 : Races

The races of the **Challenge des Monos** shall be run over a distance corresponding to a duration of 25 minutes, plus or minus 1 lap.

To be classified, each rider must have completed at least 75% of the distance covered by the winner of the race and must have crossed the finish line **within 5 minutes** of the winner.

Article 11 : Ranking

All competitors registered for the championship and qualified for the races will participate in the general classification.

The following points will be awarded for each race :

1st 25 pts	6th 10 pts	11th 5 pts
2nd 20 pts	7th 9 pts	12th 4 pts
3rd 16 pts	8th 8 pts	13th 3 pts
4th 13 pts	9th 7 pts	14th 2 pts
5th 11 pts	10th 6 pts	15th 1 pt

A specific classification will also be established for the "Mono2" category with points awarded in the same way as for the general classification and under the same conditions.

To be included in the "Mono2" classification, competitors must be registered in the "Mono2" category and ride a machine complying with the "Mono2" regulations.

The classification will be final only after homologation.

The final general classification and the "Mono2" classification will be established by adding the results obtained in all the races that the rider will have done.

Ties will be broken :

In consideration of the number of 1st, 2nd, etc. places.

The results of the last race will be decisive.

Article 12 : Controls and sanctions

During the event, several machines may be placed in a closed park on the initiative of the organisers.

The **CM2** association reserves the right to have any technical inspection carried out on any motorbike at any time during the event, without the rider concerned being able to claim any compensation, including in the event of engine failure during the said inspection.

In case of non-conformity of a machine, the rider may be downgraded from the category in which he competes and will lose any points obtained during the event, however, if he is registered in the Mono2 category, he will keep the points acquired in the Supermono category, subject to conformity to this category.

The Jury of the Stewards of the event remains sovereign as to the choice of a sanction to be applied. Any machine declared non-compliant must be brought back into conformity for the following event.

In the event of a repeat offence, the driver will be excluded from the category in which he is competing until the end of the season. If he is in the Mono2 category, he will however be able to compete in the Supermono category, if he is in the Supermono category, he will be able to compete out of the classification.

All costs relating to the checks will be borne by the rider whose machine has been declared non-compliant.

Any dispute arising from an event shall be decided by the Jury of the Sporting Commissaires of the event after advice and notification of the Technical Commissaires. In the event of a dispute over the decision, the competent body shall be the National Disciplinary and Arbitration Tribunal.

Article 13 : Prizes and awards

The **CM2** association will distribute the prizes awarded by its possible partners.

Article 14 : Claims

A written protest accompanied by a deposit of 75€ may be lodged with the race director within half an hour of the announcement of the results, if it concerns a protest relating to the classification of the event.

For an engine dismantling, it will have to be accompanied by an amount of 150€. This sum will be reimbursed if the dismantled machine does not conform or paid to the rider forced to dismantle it if conformity is recognised.

Article 15 : Application of the Regulation

In the event of a dispute concerning the interpretation of a text or if there is a difference between the present regulations and a regulation issued by the F.F.M., the federal text shall prevail. For all cases not provided for in these regulations, reference shall be made to the various federal regulations (Sporting Code, CNV General Regulations, Disciplinary Code).

Ultimately, the decision of the event's jury will prevail.

Article 16 : Insurances

The organiser of the event in which the **Challenge des Monos** is integrated has taken out insurance covering its civil liability, in accordance with article R331-30 of the sports code and the decree of 27 October 2006.

Article 17 : Partnership

Each rider wishing to take part in the **Challenge des Monos** must wear on his machine markings in the colours of the **CM2** association's partners, except for exceptions authorised by the **CM2** association. Any rider who violates this rule will be sanctioned and, in case of recurrence, excluded from the **Challenge des Monos**.

Technical Regulations of the “Challenge des Monos”

Article 1 : General information

The motorbikes competing in this challenge shall be 4-stroke single-cylinder motorbikes whose appearance shall be that of a road racing machine, i.e. conforming to diagrams A and C of the F.I.M. regulations (see appendices to these regulations).

Trails, enduro, cross, supermoto, single bike or roadsters are not allowed.

A distinction will be made between so-called "Supermono" and "Mono2" machines.

Article 2 : Tyres

The tyres must be "commercial", which means that they must appear in the manufacturers' catalogues.

Home-made re-cut tyres and trail tyres are not allowed.

If the track is recognised as "wet" by the race direction, "rain" tyres are allowed.

The electric power supply of the tire warmers is authorised on the pre-grid with their individual power supply, a generator of 2000 watts maximum (FFM regulations). No cable linking two motorbikes or other will be allowed.

In the starting grid, the use is according to the directives of the race direction.

The brand of tyres may be imposed by the CM2 association.

Article 3 : Engines

The engines must be of the 4-stroke type operating with one cylinder.

Article 4 : Fuel

The fuel must be unleaded, in accordance with F.I.M. regulations. Fuel analyses are carried out at the expense of the CM2 association, if they prove to be negative..

If they are positive, the competitor must pay the corresponding fees.

In all cases, the counter-expertise is at the competitors' expense.

Article 5 : Noise level

- **Contrôle en dynamique suivant les normes FFM en vigueur.**

[RTS Règlementation niveau sonore des machines - 25 novembre 2023.pdf \(ffmoto.org\)](#)

Article 6 : Minimum weight

The **minimum weight** of machines in running order without fuel is set at :

Category	Cylinder capacity	Weight
Supermono	< 250 cc	No limit
Supermono and Mono2	>= 250 cc and < 500 cc	No limit
Supermono and mono2	> 500 cc	No limit

Article 7 : Safety rules

Safety wire :

The safety wires must be made of stainless steel and have a minimum thickness of 6/10th mm. They must be twisted (except in exceptional cases) and pulled in the opposite direction to the unscrewing.

Hydraulic circuits :

All hydraulic and oil cooler connections, level plugs, drain plugs, oil filler plugs, access doors to an oil filter or strainer must be braked by safety wires pulled in the opposite direction to unscrewing.

Automotive type oil filters must be stopped by means of a Serflex collar and a safety wire pulled in the opposite direction to unscrewing.

The only cooling agents, other than lubricating oil, are pure water, any additive whatsoever is strictly prohibited.

Brakes :

Front caliper fixing screws must be braked by safety wire.

The front brake lever bolt must be braked with a plastic collar or brake nut.

Any lever showing significant signs of having been dropped must be replaced. Any re-welded lever will be refused.

Rear brake must be present and operational.

Handlebars :

Handlebar ends must be plugged at the ends **and free of roughness**.

The throttle must return to its original position by itself.

The rubber grips must be attached to the handlebars without risk of slipping or rotating (glued or braked with a safety wire).

All levers (clutch, brake, etc.) must end in a sphere (Ø of this sphere: 16 mm minimum).

This sphere can also be flattened, but in any case the edges must be rounded (minimum thickness of this flattened part: 14 mm). These ends must be permanently fixed and form an integral part of the lever.

A minimum gap of 30 mm between the handlebars with levers and the tank or frame is mandatory when the steering angle is at its maximum.

The steering damper must not be used as a stop.

The repair of handlebars is forbidden.

Regardless of the position of the handlebars, there must be a gap of at least 20 mm between the fairing and the ends of the handlebars or any other steering system, including any accessories attached to them.

Lever protection :

Motorbikes must be equipped with a front brake lever guard to protect the handlebar brake lever from accidental operation in the event of a collision with another machine. These guards must be mass-produced and distributed by a professional.

Contact cut :

Motorbikes must be equipped with a functioning red switch or ignition cut-off button that can be operated without letting go of the handlebars, that is located on either side of the handlebars or handlebar halves within easy reach, that is visible and functional. This circuit breaker shall interrupt the primary ignition circuit.

A circuit breaker, **not compulsory but strongly recommended**, which interrupts the primary ignition circuit and cuts off the engine when the rider leaves the machine (particularly in the event of a fall) must be installed on the motorbike.

This system can be controlled either by a cord connected to the rider or by a wireless system indicating the engine speed is mandatory on all machines (FFM speed regulations).

In all cases, the correct functioning of the circuit breaker is checked during the technical inspection.

Mudguard :

The front mudguard **is mandatory**. It must be firmly fixed with screws (no rivets or clamps).

The rear mudguard **is optional**. It must be firmly attached. **It is recommended** that it extends 8 cm under the swingarm.

Footrests :

Footrests must be at least 65 mm long and have rounded ends of at least 16 mm. They must not be slippery.

Folding footrests must be returned to their original position by a spring.

Fixed metal footrests must have a nylon or Teflon end cap with a diameter of 16 mm.

Chainguard :

A guard fixed under the swingarm, preventing the foot or hand from passing between the lower strand of the chain and the rear sprocket, is mandatory.

It must be made of a Teflon or composite material with rounded edges and a thickness of at least 5 mm and be firmly attached to the swingarm with screws or steel rivets.

A protection of the gearbox output pinion must be present, **including for motorbikes equipped with a fairing**.

A heel guard shall be present on the footplate on the drive chain side.

Collection bins :

A **watertight** drip tray with a minimum capacity of 3 litres and greater than 2/3 of the total capacity of the lubricating and cooling fluids must be placed under the engine crankcase and securely fastened (NO TIGHTENERS OR WIRE) or be part of the fairing for machines that are equipped with one.

No opening in the drain pan within 50 mm of the lower fairing is permitted.

Plugs are not permitted.

Great care will be taken with these bins by the technical commissioners. Symbolic" bins will not be accepted.

The tightness can be checked.

Sniffers and air vents :

The oil breather hose, if not connected to the air box, must end in a single container of MINIMUM 0.8 L. The connection must be watertight. The container may be vented at the top. This vent must end either on the exhaust pipe or at the inlet of the carburettors.

The battery vent should terminate in an acid-resistant plastic container of at least 0.2 L.

Fuel tanks with breather tubes must end in a recuperator with a minimum capacity of 250 cc, including when a non-return valve is used.

The collector must be made of a suitable material.

Radiator and carburettor vents must be vented into flasks (250 cc) of suitable material.

Oil coolers :

Oil coolers should be fitted with a wire mesh guard and securely fixed to protect them from impacts and falls.

Exhaust system :

The end of the exhaust or silencer must not extend beyond the **vertical tangent** of the rear tyre.

The outlet must be **horizontal** with a **maximum upward inclination of 10°** and a minimum length of 3 cm.

The outlet edges of silencers shall be **rounded or protected**.

Fasteners :

In particular, the saddle, fairing, drip tray and exhaust pipe must be securely attached.

Electrical harnesses :

Connections must be made with crimped or soldered connectors and properly insulated. The bundle must be fixed to the frame with plastic collars (wires not crushed on the frame).

Tank :

Compliant with the new FFM requirements for 2024

It must be securely fixed.

All fuel tanks must be completely filled with fire retardant (open cell structure, e.g. Explosafe®).

The filler cap must not protrude from the upper edge of the tank (risk of tearing off), for older motorbikes an exemption may be granted.

The tank must be watertight.

Fairing :

All fairing components must be securely attached.

Fairing screens must have rounded edges.

Engine Crankcases :

All engine crankcases containing oil and likely to come into contact with the track as a result of an accident must be protected by a metal or composite housing.

All these guards must be correctly and securely fixed by at least two fixing screws which are also fitted to the original engine covers or retained by plates or bars screwed to fixed points on the engine or frame.

Aluminium or steel protective plates and/or bars are also permitted.

All such devices must be designed to withstand impact, abrasion and damage from being dropped.

Crutch holders :

Crutch holders shall be made of aluminium, nylon, Teflon or equivalent material and shall have the following maximum dimensions :

- Diameter 30 mm, length 40 mm, fixing screw recessed.

Frame guards :

The sides of the frame can be protected by carbon kevlar composite protections, these protections will follow the shape of the frame.

The fixing screws should be recessed into this material.

External starters :

This device applies to all external starting systems with internal combustion engines that start the motorbike by driving the rear wheel.

- Each pitcher must wear the race number of the driver to whom he is attached.

- Each launcher shall be equipped with a safety contact system: When the operator releases the launcher, it shall stop automatically.

- Operators should be experienced in the use of the launcher.

These points will be checked during the technical inspections.

The launchers and their operators are under the responsibility of the pilot in charge.

In case of non-compliance, the launcher will not be allowed to be used in pre-grid.

Red tail light :

Complies with the new 2024 FFM requirements.

All motorbikes must have a working red light mounted on the rear of the machine. This light must be switched on as soon as the track is declared wet.

The direction of the rear lighting must be parallel to the axis of the machine (in the direction of travel) and clearly visible from the rear at least 15° to the left and right of the machine axis.

The rear light should be mounted as close as possible to the rear end of the machine (seat backrest).

In the event of a dispute over the mounting position and/or visibility, the decision of the Technical Manager shall prevail.

The Technical Manager may reject any lighting system that does not meet safety requirements.

The red light must be composed of 6 leds with a power of 0.8 to 1.8 watt per led.

The power supply must be continuous, this safety rear light must not be flashing on the track.

Flashing is allowed in the pit lane when the speed limiter is active.

The power supply for the rear safety lamp must be separate from that of the motorbike.

The rear light control switch must be fitted as close as possible to the handlebars.

Others :

The following must be removed :

Crutch(s),

Headlights,

Turn signals and rear light,

Rear-view mirrors,

Passenger footrests,

Number plate,

Any metal object protruding from the machine.

All aggressive accessories such as steering damper rods, chain tensioners, etc. must be protected by a rubber end cap (hose or other).

Protections such as casters, pads, etc. must not extend more than 2cm from the fairing or the widest point of the motorbike body (excluding handlebars).

Article 8 : Race number plates

Motorbikes must be equipped with matt black plates (ref. RAL 6002) with white numbers for Mono2 riders and yellow numbers for other riders.

The plates must be placed in front, one in the centre of the fairing or one on each side, and at the bottom of the fairing on each side as well (see attached plan).

The dimensions of all figures applied to the front are :

Minimum height : 140 mm

Minimum width : 80 mm

Minimum line width : 25 mm

The dimensions of all figures applied to the side are :

Minimum height : 120 mm

Minimum width : 60 mm

Minimum line width : 25 mm

The numbers are assigned arbitrarily or at the request of the drivers according to the order of registration to the 2024 challenge knowing that the number **1** is reserved for the driver ranked in 1st place in the general ranking of the 2023 challenge. In case he refuses this possibility, the number 1 will not be attributed.

The numbers thus defined will be kept throughout the year.

Article 9 : Supermono

Machines in the Supermono category will have the following preparation limits :

The use of alloy and titanium bolts and nuts is **prohibited** for the bike and engine. They are **allowed** for the fairings.

Braking: carbon disc(s) **prohibited**.

Mandatory "wristband" type handlebars in accordance with F.I.M. Diagram A.

Crankcases* and cylinder heads "cut from the ground" **prohibited**.

**(Engine crankcase means the crankcase enclosing the gearbox and the gearbox, the covers do not fall under this definition).*

Power supply : **free**.

Air box : **free**.

Wheels : **free** (Carbon rims must be made by a recognised manufacturer, and the rider must provide a certificate from the manufacturer. The rider must provide a certificate from the manufacturer for rims showing signs of repair).

Shifters: **free**.
Telemetry systems: **prohibited**
Data acquisition systems : **free**
Original anti-skid systems : **authorized**
Front mudguard : **mandatory**, (cf. diagram A F.I.M.)

Article 10 : Mono2

All air- and oil-cooled engines are allowed, regardless of their capacity.
Liquid-cooled engines over 500cc must be included in the list of approved engines in the annex.

Article 11 : Table of modifications allowed on Mono2

– **Frame** : From the series, **authorised** without restriction. Race or home-made frames are **allowed** with the **obligation** to be equipped with a minimum tyre size of 110 for the front and 140 for the rear. (The organizers of the Challenge des Monos reserve the right to veto the acceptance of this type of frame).

The use of alloy and titanium bolts and nuts is **prohibited** for the bike and engine. They are **allowed** for the fairings.

Rear loop : **free**,

Swingarm : **free**.

Fork : **free**.

Rear shock : **free**.

Mandatory "wristband" type handlebars in accordance with F.I.M. Diagram A.

Fuel tank : **free**.

Oil tank : the removal or replacement of the oil tank is permitted without reducing its capacity. An oil cooler may be installed. Machines modified in this way shall be presented at each technical inspection after removal of the covering elements masking the oil circuit.

Seat : **free**.

Foot controllers : **free**.

Wheels : Within the limits of the minimum tyre size 110 for the front and 140 for the rear. **Carbon rims are not allowed**.

Braking : carbon discs **prohibited**.

Front mudguard : **mandatory**, (cf. diagramme A F.I.M.)

Rev counter : **free**.

Fairing : **free**.

Electrical harness : **free**.

Ignition : **free**.

Air filter : **free**.

Air box : **free**.

Power supply : carburetors **free, original** injection for those models that are equipped with it.

Exhaust system : **free** within the limits of Article 4 (noise level).

Any non-compliant motorbike will be subject to article 12 of the general regulations (controls and sanctions).

Article 12

Anything that is not permitted and specified in these rules is prohibited.

Any dispute shall be settled in accordance with the F.F.M. sporting code and its annexes.

Article 13

On the report of the technical steward and after the opinion of the jury, the **CM2** association reserves the right to refuse any machine that does not meet all the safety criteria or whose design could jeopardize the safety of other competitors.

ANNEXES

CALENDAR OF THE CHALLENGE DES MONOS 2024

DATE	CIRCUIT	EVENT	NUMBER OF MACHINES ALLOWED FOR THE RACE
18 / 19 May	Pau	WERC	35
15 / 16 June	Navarra (Spain)	WERC	41
6 / 7 July	Carole	WERC	30
7 / 8 September	Anneau du Rhin	WERC	44
7 / 8 October	Alès	WERC	42

Note :

2 races per event, all results will be retained..

RATES FOR THE CHALLENGE DES MONOS 2024

SIMPLE MEMBERSHIP (without registration to the Challenge)	
	25,00 €
Send the membership form and cheques made out to CM2 to the following address : Mr Guy FITTE 37 rue Albert Gautier 28130 PIERRES	

SUBSCRIPTION / REGISTRATION (as a membership)	
	190,00 €
DEPOSIT	
	380,00 €
Send the membership form and cheques made out to CM2 to the following address : Mr Guy FITTE 37 rue Albert Gautier 28130 PIERRES	

RESERVATION		
Rider Registered for the year	120,00 €	1 cheque
COMMITMENT		
Rider Registered for the year	167,00 €	1 cheque
Rider with trial formula	390,00 €	1 cheque
PENALTY FOR LATE PAYMENT		50,00 €
Send the membership form and cheques made out to CM2 to the following address : Mr Guy FITTE 37 rue Albert Gautier 28130 PIERRES		

Lists of engines allowed in MONO2 category

BRAND	MODELS Authorised above 500cc	MODEL Authorised with original diameter cylinder head exhaust pipes
APRILIA		Pegaso 650
BIMOTA		BB1
BMW		F650, F650CS, F650GS, F650ST
GILERA	600 Nordwest, RC600, XRT600	
KAWASAKI	KLR600, KLR650, Tengai	
MZ, Muz	600 Skorpion, Baghira, Mastiff	
ROTAX		605
YAMAHA	660SZR, XTX, XTZ	

Notes :

All single-cylinder 4-stroke air or air/oil cooled engines are allowed.

All 4-stroke single-cylinder engines with a capacity of 500cc or less are allowed,

All liquid-cooled engines over 500cc not included in this list **are forbidden in Mono2.**

DIAGRAMME A

DIAGRAM 1

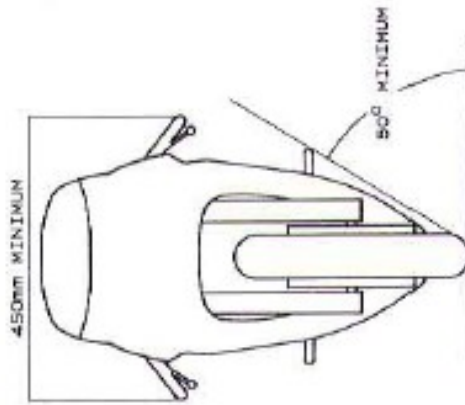
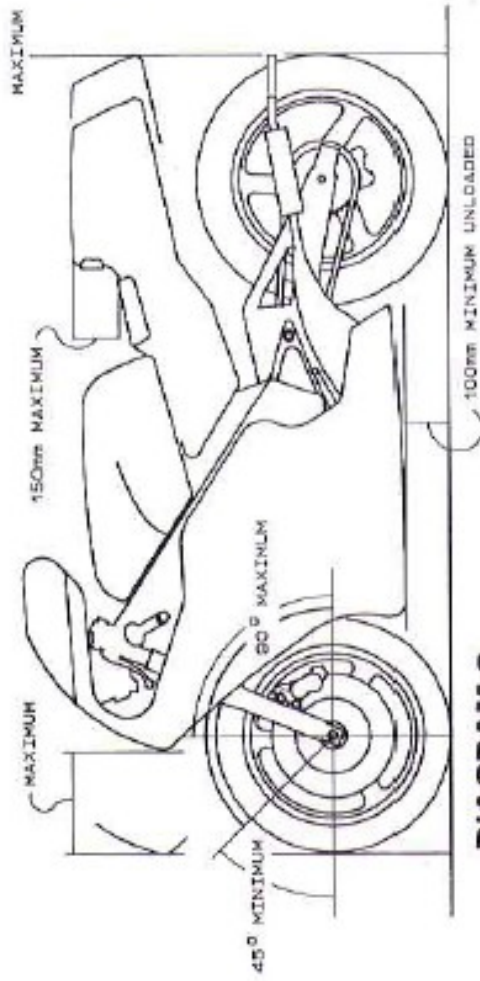

DIAGRAM 2



**DIAGRAM 4
NUMBERPLATES**

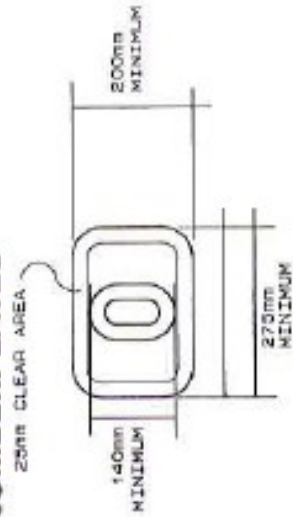

DIAGRAM 3



DIAGRAMME C



BAC de RETENTION

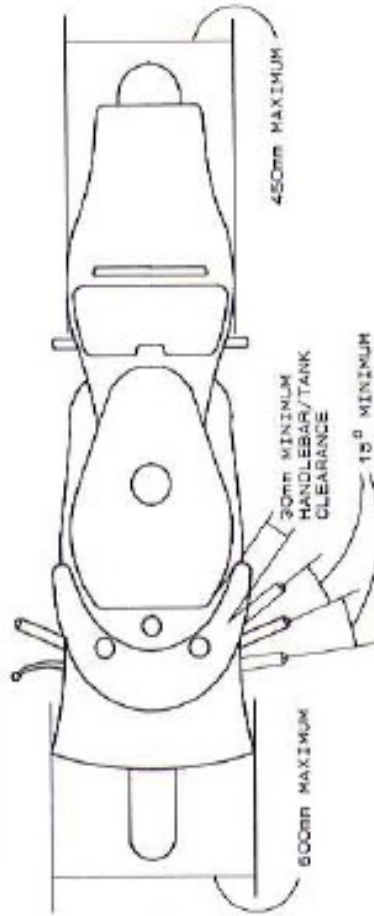
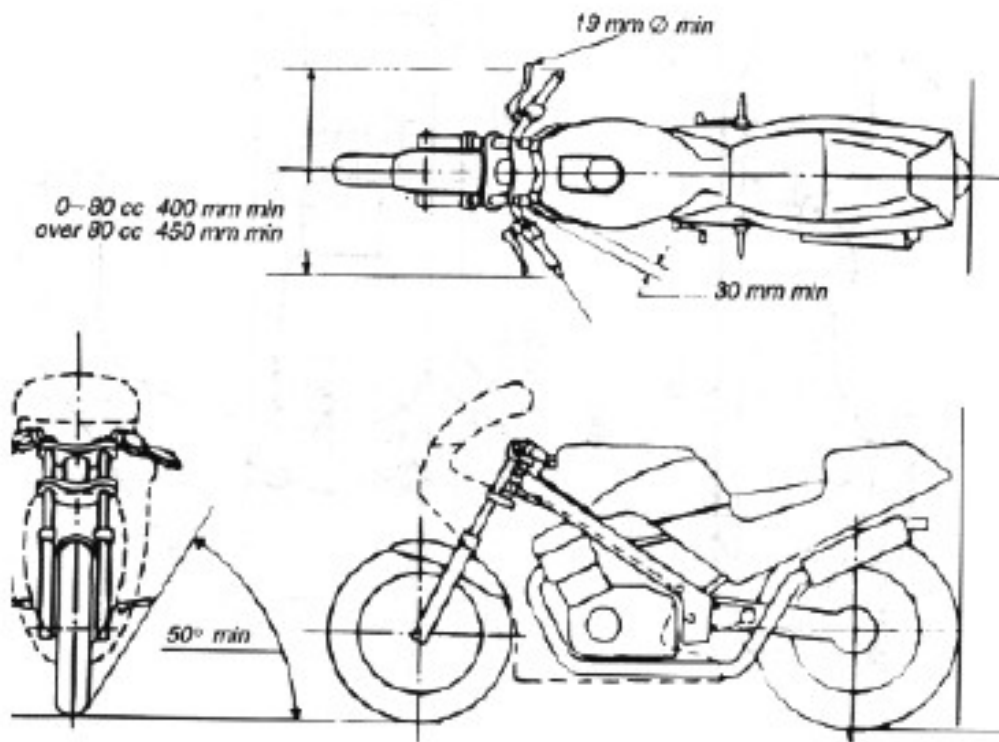
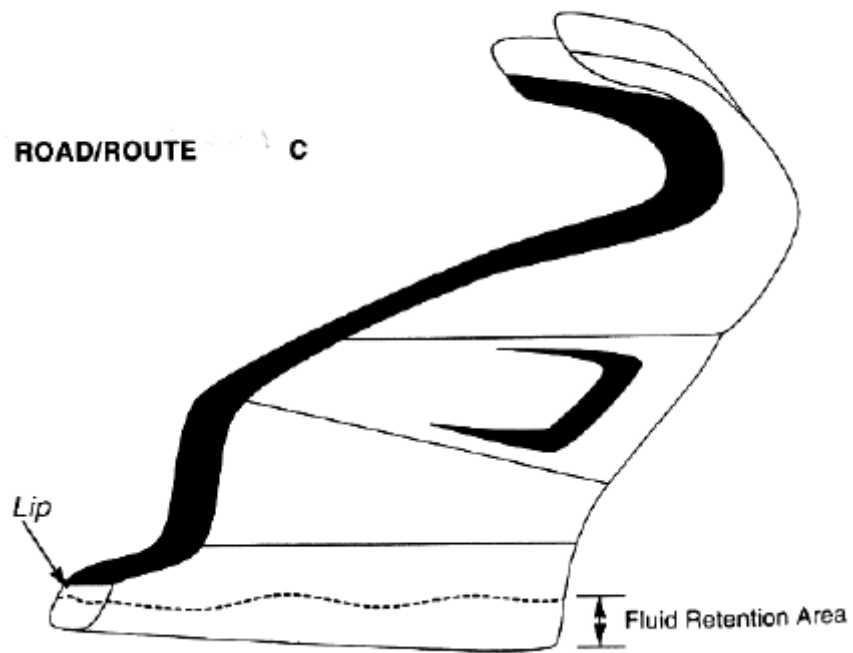

Plaque et Numéro



Les numéros devront être réalisés dans l'une des polices, ci-dessous :

Arial Black

0 1 2 3 4 5 6 7 8 9

Arial Black italique

0 1 2 3 4 5 6 7 8 9

Haettenschweiler

0 1 2 3 4 5 6 7 8 9

Haettenschweiler italique

0 1 2 3 4 5 6 7 8 9

Impact

0 1 2 3 4 5 6 7 8 9

Impact italique

0 1 2 3 4 5 6 7 8 9

En cas de litige concernant la lisibilité des numéros, la décision du Directeur Technique fera foi.